



**Technical Data / Fiche Technique / Technische Daten / Datos Técnicos**

Spill Pallets ■ Palettes de rétention ■ Auffangwannen ■ Palets para derrames

**SJ-100-001 / SJ-100-002**



**SJ-100-001**



**SJ-100-002**















**Features/Caractéristiques/Merkmale/Características**

Spill pallet for 2 drums • Removable platform • For static spill containment • Remove drums before fork lifting • Compatible with most forklifts and pallet trucks • Made from PE - 100% recyclable.

Palette de rétention pour stocker 2 fûts • Caillebotis amovible • Usage statique uniquement: ne peut pas être utilisée pour transporter les matières dangereuses (fûts) • Ceux-ci doivent être retirés avant toute manipulation par chariot élévateur ou transpalette • Manipulable avec la plupart des chariots élévateurs et transpalettes • 100% PE • 100% recyclable.

Auffangwanne für 2 Fässer • abnehmbare Lochplatte • für den stationären Gebrauch • vor Transport mit Stapler Fässer entfernen • für die meisten Stapler/Handhubwagen geeignet • aus PE - 100%ig recycelbar.

Palet de derrames para 2 bidones • Cubierta desmontable • Palet fijo para derrames • Quite los bidones antes de utilizar una carretilla elevadora • Para usar con la mayoría de carretillas elevadoras y transpaletas • Fabricado en polietileno (PE) 100% reciclable.

	 mm	 mm	 mm	 kg		 mm				A/B mm	C/D mm	 kg
SJ-100-001	440	1300	750	20.5		630 x 1180 x 55		250	2	190 / 815	-	650
SJ-100-002												



FM12422

**Jonesco (Preston) Ltd.**  
 Pittman Way  
 Fulwood  
 Preston PR2 9ZD  
 England  
 Tel: +44 (0) 1772 704488  
 Fax: +44 (0) 1772 702209

**Jonesco S.A.R.L.**  
 SECLIN UNEXPO  
 1524 Avenue de l'Épinette  
 59113 Seclin  
 France  
 Tel: +33 (0) 3 20 32 1111  
 Fax: +33 (0) 3 20 90 6210  
 SARL au capital de 8,000 euros



www.jonesco-plastics.com



**Technical Data / Fiche Technique / Technische Daten / Datos Técnicos**

Spill Pallets ■ Palettes de rétention ■ Auffangwannen ■ Palets para derrames

**SJ-100-001 / SJ-100-002**

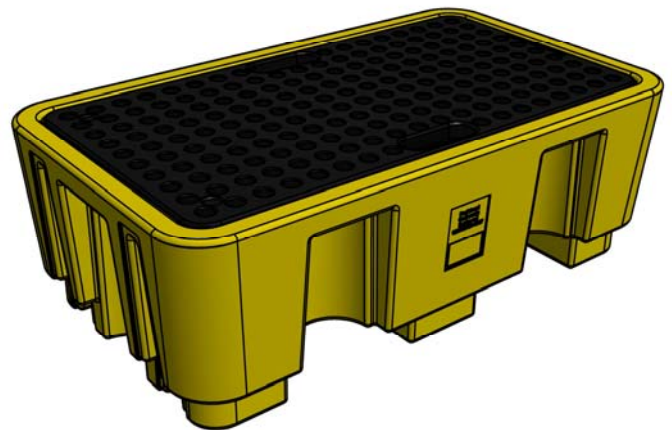
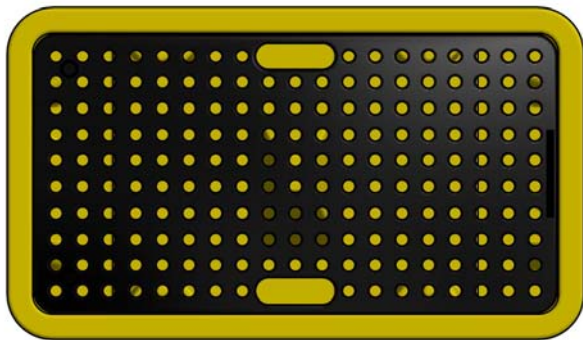
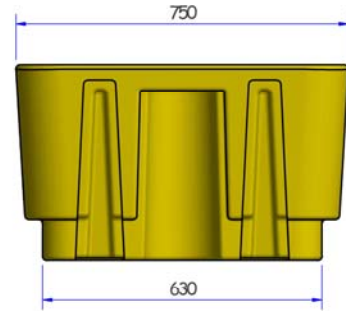
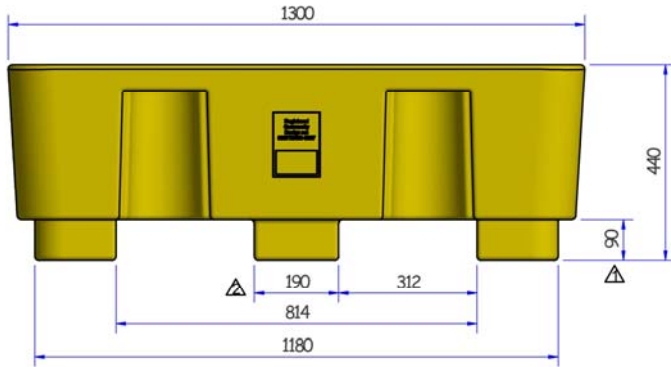

**SJ-100-001/002 - 5 units per pallet / 5 pièces par palette / 5 Teile pro Palette / 5 piezas por palé**

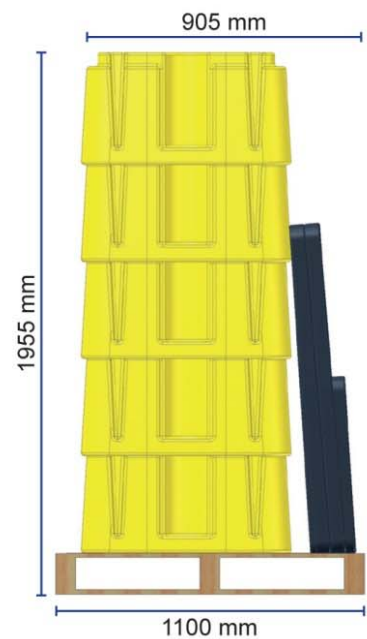
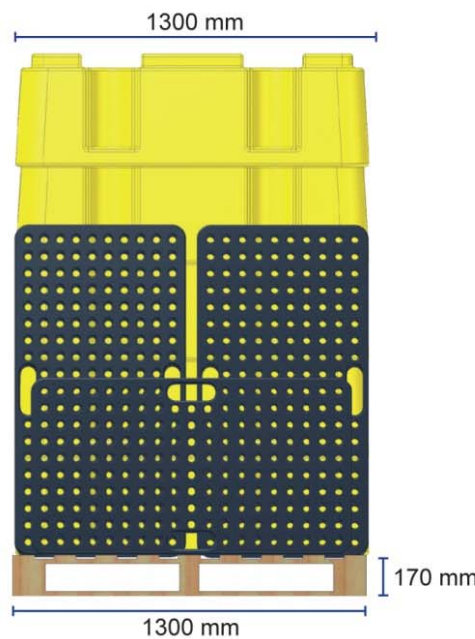

FM12422

**Jonesco (Preston) Ltd.**  
 Pittman Way  
 Fulwood  
 Preston PR2 9ZD  
 England  
 Tel: +44 (0) 1772 704488  
 Fax: +44 (0) 1772 702209

**Jonesco S.A.R.L.**  
 SECLIN UNEXPO  
 1524 Avenue de l'Épinette  
 59113 Seclin  
 France  
 Tel: +33 (0) 3 20 32 1111  
 Fax: +33 (0) 3 20 90 6210  
 SARL au capital de 8,000 euros



www.jonesco-plastics.com