



**JONESCO**



# AWAYWASH

CONCRETE WASHOUT SYSTEM



AWAYWASH is the first on-board polyethylene system for ready-mix concrete truck chute washout. This patented design allows to wash the chute in compliance with environmental requirements while avoiding risks of contamination and penalties/ fines. The product is light, sturdy and easy to maintain as concrete does not adhere to it.

The unique design collects the washout waste and separates the coarse material in a robust sieve designed for easy emptying. At the batching plant, the containment tank is simply emptied through gravity by lowering the hose towards the settlement pits. There are no mechanical parts that could jam or require costly maintenance.



CCRT-TS-YE + CCRT-K

- Avoids chute washout water spillage on the ground
- Allows to wash the chute anytime and anywhere
- Time saving : No waiting at washout areas on work sites
- Allows to catch and re-use the washout water
- Facilitates compliance with environmental regulations
- Lighter than metal alternatives, optimises payload
- Trouble free patented design with EU Design registration
- Separates aggregate from the waste water allowing easy recycling and disposal



CCRT-TS-YE + CCRT-K



CCRT-S-YE



CCRT-S-YE



CCRT-S-YE

- Removes harmful washout water from construction sites
- Reduces water treatment/disposal related costs
- Prevents contamination of underground and surface water
- Easy to install, handle and use
- No mechanical parts
- Low maintenance
- Easy to clean : non-adherent/non-stick material and smooth surfaces
- Fully recyclable, chemical resistant, UV-stabilised PE



CCRT-K

- Various fitment options (M8 x 15 mm max)
- Bead feature allows easy alignment of conspicuity tape
- Conspicuity tape supplied as standard
- Integrated sieve with incorporated handles acts as a water baffle during transit and prevents any water escaping
- 750 mm flexible hose for easy emptying
- Can be retro-fitted
- Industrial quality mouldings, resists knocks and scuffing



CCRT-K



CCRT-TS-YE + CCRT-K



CCRT-TS-YE + CCRT-K

	 EAN-13				 mm	 mm	 mm	 kg	
CCRT-TS-YE	5055644212017	✓	✓	-	525	1860	760	21.5	55
CCRT-S-YE	5055644212031	-	✓	-	240	385	385	1.5	-
CCRT-K	5055644215018	-	-	✓	-	-	-	1.2	-

#### NETREGS:-

Cement powder, workable concrete and grout are extremely alkaline. Concrete also contains chromium, which is potentially polluting not only to watercourses but also to groundwater. Trucks, hoppers, mixers and concrete pumps that have contained concrete must be washed out in a contained area away from watercourses, surface water drains, storm water drains, grids and channels to prevent pollution. Where possible, store and reuse washout water.

#### Washing out ready-mixed concrete trucks on-site

The Environment Agency publishes Pollution Prevention Guidelines, including PPG6 'Working at construction and demolition sites', a guideline that is intended to assist with those in the construction and demolition industry.

This states that precautions must be taken to ensure the complete protection of watercourses and groundwater against pollution. Further, it states that **'Suitable provision should be made for the washing out of concrete mixing plant or ready-mixed concrete lorries. Such washings must not be allowed to flow into any drain or watercourse.'** Ready-mixed concrete trucks should not be allowed to wash out anywhere other than the areas designated for the purpose.

**Our solution solves this issue by taking the waste back to the plant that can easily handle it.**

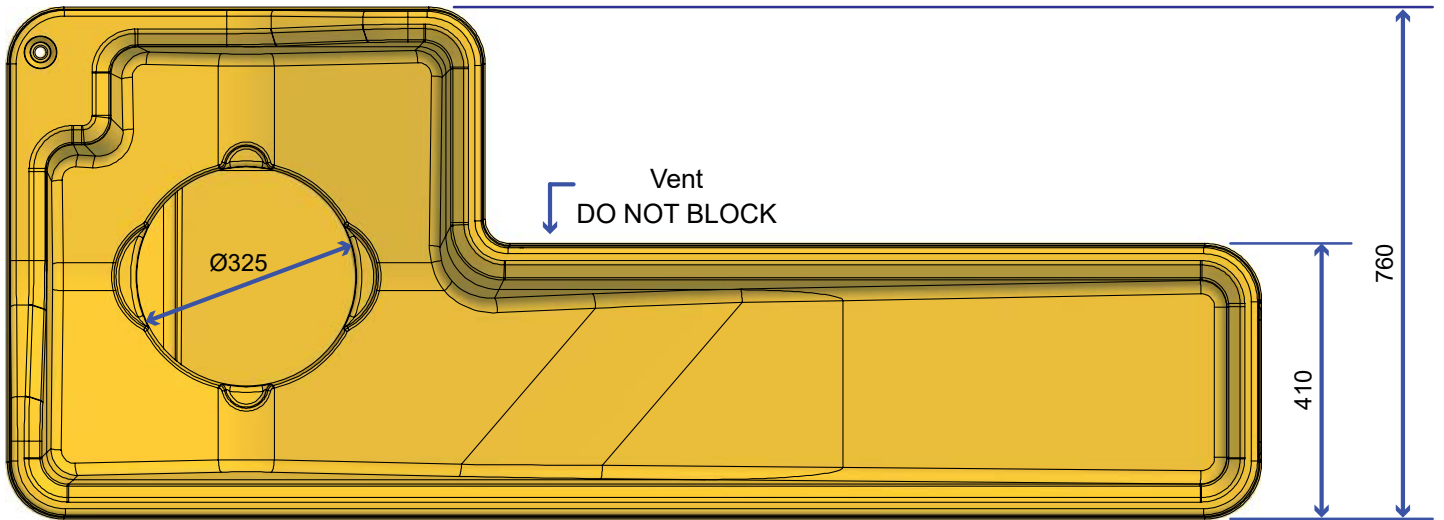
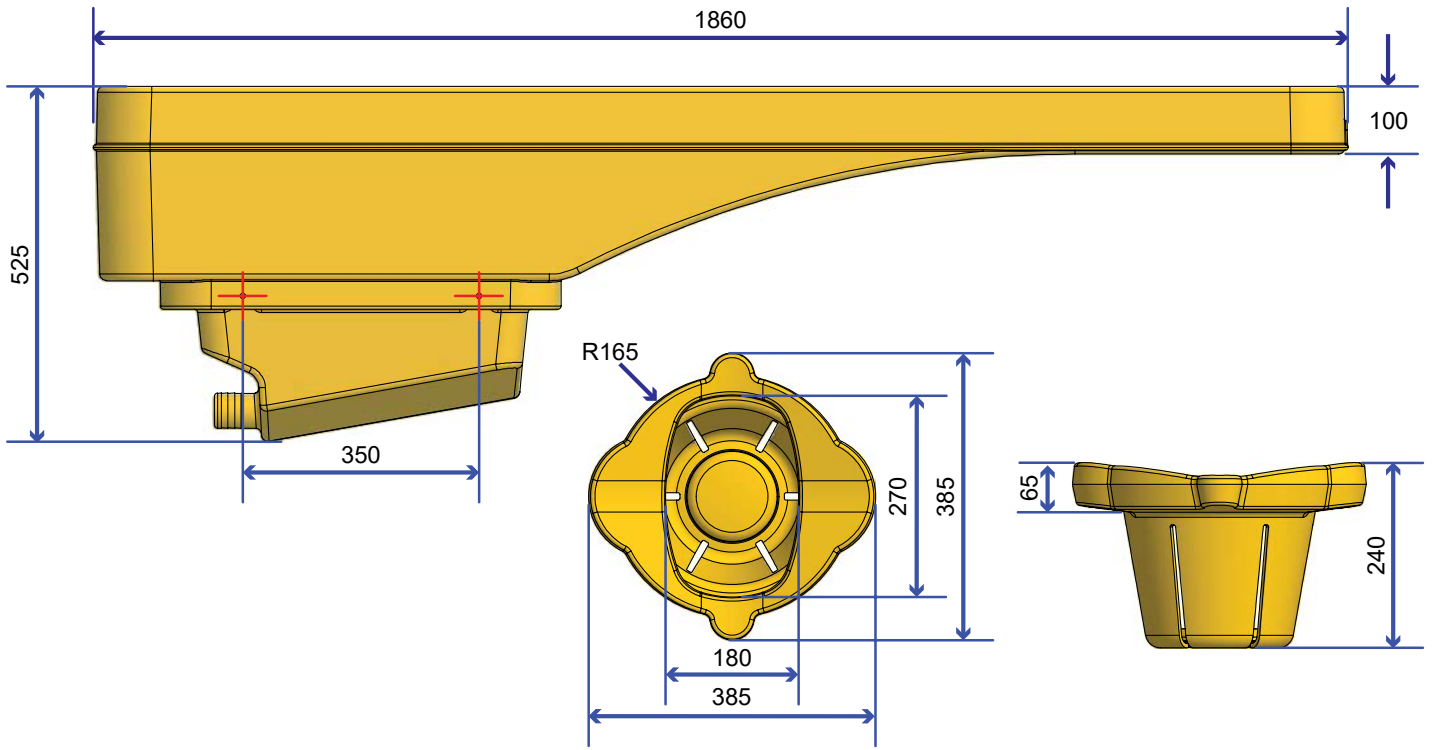

CCRT-TS-YE + CCRT-K