





JFEX01

For wall mounting only • Not for use on commercial vehicles • For in-door/out-door storage of Fire extinguishers • Strengthened base to accommodate extinguisher, no additional fixings required • Detachable lid for immediate access in case of emergency • Rubber fastening toggles • Textured surface finish • Economical • UV-stabilized to retain colour fastness • Fire extinguisher label.

Para colgar sólo en la pared • No aptos para la instalación en vehículos • Para ubicar extintores de 6 kg en el interior o en el exterior • Gracias a su base reforzada los accesorios de montaje adicionales no son necesario • Tapa roja desmontable por acceso rápido en caso de emergencia • Fijación de tapa de caucho • Superficie texturada • Económico • Color stabil y resistente a los rayos ultravioleta (UV) • Etiqueta de extintor incluida.



Type		
JFEX01		

JFEX03





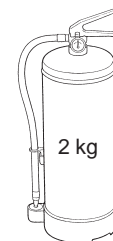

Plastic box for extinguishers • Ideal for use in truck cabs, houses, mobile homes etc • Detachable lid for immediate access in case of emergency.

Armario de plástico • Por uso en la cabina de camiones, casas o casas móviles etc • Tapa roja desmontable por acceso rápido en caso de emergencia.



JFEX03



Type	 mm	 mm	 mm	 mm	 mm	 mm
JFEX01	560	640	190	250	180	250
JFEX03	405	415	185	210	120	145

56 Series

Serie 56

500	610	395	500	140	190

Type			
HRE56			
HRR56			

Suitable for in-door/out-door storage of hose reel and nozzle • woven strap to secure contents • Water resistant seal • Can also be used as key cabinet, Emergency plan storage box or first aid kit box.

Para almacenamiento manguera y lanza dentro o fuera de edificios • Correa tejida para asegurar contenido • Precinto de neopreno • Se puede utilizarlo también por el almacenaje de planos d'emergencia o botiquín de primeros auxilios.



HRE56



HRE56

68 Series

Serie 68

585	680	230	260	220	260

Type		
JBTB68		
JBTE68		

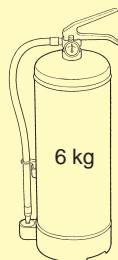

6 kg

Truck or wall mounting • Neoprene seal • Detachable lid • Buckle Web Strap • Plastic toggle and Lynch pin as standard* • FE label supplied loose.

Para instalación en vehículos o edificios • Precinto de neopreno • Tapa desmontable • Correa de seguridad reforzada* • Precinto y pasador con cada cofre • Etiqueta de extintor incluida.

JBTB68

JBTE68



*Lynch pin/Clave de seguridad

70 Series

Serie 70

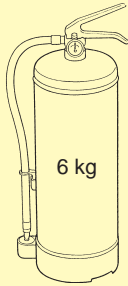

mm	mm	mm	mm	mm	mm
625	700	260	320	195	255

Truck or wall mounting • Rubber seal and polycarbonate windows • Left or right hinged mounting • Buckle Web Strap • Plastic toggle, lynch pin and hinge pins as standard • FE label supplied loose • Optional extra: Factory fitted alarm, coding example: JBWE70A.

Para instalación en vehículos o edificios • Precinto de caucho y ventanillas de policarbonato • Montaje reversible apertura hacia derecha o izquierda • Correa de seguridad reforzada • Pasador de seguridad, bisagra y cierre de plástico incluido • Etiqueta de extintor incluida • Opcional: Alarma de serie.



JBWE70

Type			
JBWB70	●	●	✓
JBWE70	●	●	✓
JBWF70^	●	●	
JBWR70	●	●	✓
JBWS70^	●	●	
JBXB70*	●	●	✓
JBXE70*	●	●	✓
JBXR70*	●	●	✓

*Internal Rubber Restraints
*Correa de seguridad en caucho

83 Series

Serie 83

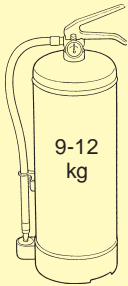

mm	mm	mm	mm	mm	mm
755	830	270	330	200	330

Truck or wall mounting • Rubber seal and polycarbonate windows • Left or right hinged mounting • Buckle Web Strap • Plastic toggle, lynch pin and hinge pins as standard • FE label supplied loose • Optional extras: Factory fitted alarm.

Para instalación en vehículos o edificios • Precinto de caucho y ventanillas de policarbonato • Montaje reversible apertura hacia derecha o izquierda • Correa de seguridad reforzada • Pasador de seguridad, bisagra y cierre de plástico incluido • Etiqueta de extintor incluida • Opcional: Alarma de serie.

Type			
JBXB83	●	●	✓
JBXE83	●	●	✓
JBXF83^	●	●	
JBXR83	●	●	✓



JBXB83

^ Wall mounting only
^ Para colgar sólo en la pared

73 Series

Serie 73

						\varnothing max	
mm	mm	mm	mm	mm	mm	mm	mm
625	730	350	435	225	290	200	610

Suitable for use with cartridge and horn extinguisher • For extinguishers up to 12 kg • Truck or wall mounting • Rubber seal and polycarbonate windows • Left or right hinged mounting • Buckle Web Strap • Plastic toggle, Lynch pin and hinge pins as standard • FE label supplied loose • Optional extras: Feet for use when free-standing (Kit 52), Factory fitted alarm.

Apto para extintores de 12 kg con cartucho y bocillas de descarga • Para instalación en vehículos o edificios • Precinto de caucho y ventanillas de policarbonato • Montaje reversible apertura hacia derecha o izquierda • Correa de seguridad reforzada • Pasador de seguridad, bisagra y cierre de plástico incluido • Etiqueta de extintor incluida • Opcional: Pie de soporte (KIT52), Alarma de serie.



JBDE73

Type			
JBDE73	●	●	✓
JBDR73	●	●	✓

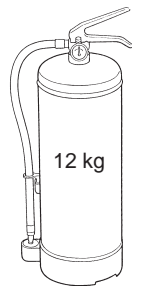

72 Series

Serie 72

mm	mm	mm	mm	mm	mm
650	720	530	585	210	270

For 2 extinguishers up to 12 kg • Truck or wall mounting • Rubber seal and polycarbonate windows • Left or right hinged mounting • Buckle Web Strap • Wooden base plate • Plastic toggle and Lynch pin as standard • FE label supplied loose • Optional extras: Feet for use when free-standing (Kit 52), Plastic Shelf (KIT SHEL72), Factory fitted alarm.

Apto para 2 extintores de hasta 12 kg • Para instalación en vehículos o edificios • Precinto de caucho y ventanillas de policarbonato • Montaje reversible apertura hacia derecha o izquierda • Base de Madera. Correa de seguridad reforzada • Pasador de seguridad, bisagra y cierre de plástico incluido • Etiqueta de extintor incluida • Opcional: Pie de soporte (KIT52), Estanterías de plástico (KITSHEL72) Alarma de serie.



JBDB72

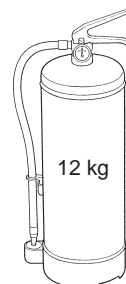

Type			
JBDB72	●	●	✓
JBDE72	●	●	✓
JBDR72	●	●	✓

85 Series

Serie 85







For the storage of Fire extinguishers, Breathing apparatus equipment. Firehose reels, First aid equipment and materials • 'T' handle door lock • Rubber seal and polycarbonate windows • Left or right hinged mounting • Wooden base plate • Fire extinguisher, fire hose reel, breathing apparatus and first aid labels • Optional Extra: Factory fitted alarm, 2 wooden shelves (Kit 57), 2 plastic shelves (KIT SHELF85).

Armario multiusos-para el almacenaje de extintores, equipamientos respiratorios, mangueras • botiquín de primeros auxilios • Cerradura con llave y tirador en forma de T • Precinto de caucho y ventanillas de policarbonato • Montaje reversible apertura hacia derecha o izquierda • Base de Madera • Etiquetas de extintor, manguera, equipamientos respiratorios y primeros auxilios incluida • Opcional: Alarma de serie • 2 Estanterías de madera (KIT57), 2 Estanterías de plástico (KITSHELF85).

Type		
JBDB85	●	●
JBDE85	●	●
JBDG85	●	●
JBDR85	●	●



JBDE85

					
760	850	530	565	300	375

90 Series













Serie 90

For in-door/out-door storage of Fire extinguishers, Hose reels, Breathing apparatus, Chemicals and spillage equipment • Wall mounted or free-standing • Rubber seal and polycarbonate windows • Left or right hinged mounting • Plastic locks and key compartment with Break-glass facility (2 keys, 2 clear plates and 2 fasteners supplied for self-assembly) • Wooden base plate • FE and hose reel label supplied loose • Optional extras: Factory fitted alarm, 2 wooden shelves (Kit 90), Break-glass spare kit (Kit 81).

Armario multiusos-para el almacenaje de extintores, equipamiento protector respiratorio, mangueras • botiquines de primeros auxilios y artículos par protección ambiental dentro o fuera de edificios • Fijación en pared o directamente el suelo • Precinto de caucho y ventanillas de policarbonato • Montaje reversible apertura hacia derecha o izquierda • Cerraduras de plástico y compartimento para llaves con ventanilla rompible • (2 llaves, 2 ventanillas rompibles y 2 tornillos de plástico montable) • Base de madera • Etiquetas de extintor y manguera incluida • Opcional: Alarma de serie. 2 Estanterías de madera (KIT90), Kit ventanilla rompible (KIT81).



JBKE90

Type			
JBKE90	●	●	 
JBKG90	●	●	  
JBKR90	●	●	 
JBKY90	●	●	 

					
820	900	850	930	340	420

95 Series

Serie 95

mm	mm	mm	mm	mm	mm
915	950	360	445	195	280

Designed primarily for a 5 kg CO₂ extinguisher with a large nozzle • Rubber seal and polycarbonate windows • Left hinged mounting • Plastic toggles and lynch pins OR plastic locks and key compartment with Break-glass facility (2 keys, 2 clear plates and 2 fasteners supplied for self-assembly) • FE label supplied loose.

Apto para extintores de 5 kg CO₂ con bocilla de descarga grande • Precinto de caucho y ventanillas de policarbonato • Apertura de puerta hacia la izquierda • Correa de seguridad reforzada • Cierre y clave de seguridad plástico de serie o cerraduras con llave y ventanilla rompible • Etiqueta de extintor incluida • Opcional: Pie de soporte (KIT52), Alarma de serie.

Type						
JBWB95	●	●	●	●	●	●
JBWE95	●	●	●	●	●	●
JBWR95	●	●	●	●	●	●
JBKB95	●	●	●	●	●	●
JBKE95	●	●	●	●	●	●
JBKR95	●	●	●	●	●	●



JBWE95



JBKE95

SAFETY BOXES

ARMARIOS DE SEGURIDAD

70/72/83/85/90 Series



Also available as Safety Boxes - see relevant description for information, noting that Safety Boxes come without any restraints/straps.

Serie 70/72/83/85/90

Nuestros armarios son disponibles también como armarios de seguridad-véase descripción para mas información. Tenga en cuenta que estos armarios no contienen correa de seguridad.



JBWA70

Type		
JBWA70	●	●
JBDA72	●	●
JBXA83	●	●
JBDA85	●	●
JBKA90	●	●



JBDA72



JBDA72

MILITARY BOXES

ARMARIOS POR USO MILITAR

NATO approved and specified for 5 years-Contract A314062/B

Aprobación de la OTAN durante 5 años-Contrato A314062/B

Type		NATO. No Référence OTAN NATO-Nr.		
JBWM70KZ	KIT56	6MT1/2540-99-891-7436	●	●
JBWE70KZ	KIT56	6MT1/2540-99-417-8725	●	●
JBXF83	KIT56	4210-17-054-9939	●	●



JBWM70KZ

K Series

Serie K

For in-door/out-door storage of Fire extinguishers, Hose reels, Breathing apparatus, Chemicals and spillage equipment • Wall mounted or free-standing • Rubber seal and polycarbonate windows • Left or right hinged mounting • Plastic locks and key compartment with Break-glass facility (2 keys, 2 clear plates and 2 fasteners supplied for self-assembly) • Wooden base plate[^] • Label supplied loose • Optional extras: Factory fitted alarm (KIT ALARM), Break-glass spare kit (Kit 81).

Armario multiuso-para el almacenaje de extintores, equipamiento protector respiratorio, mangueras • botiquines de primeros auxilios y artículos par protección ambiental dentro o fuera de edificios • Fijación en pared o directamente al suelo • Precinto de caucho y ventanillas de policarbonato • Montaje reversible apertura hacia derecha o izquierda • Cerraduras de plástico y compartimento para llaves con ventanilla rompible • (2 llaves, 2 ventanillas rompibles y 2 tornillos de plástico montable) • Base de Madera[^] • Etiqueta incluida • Opcional: Alarma de serie (KITALARM), Kit ventanilla rompible (KIT81).

[^] JBKE90 only / JBKE90 Sólo

Type	mm	mm	mm	mm	mm	mm
JBKE70	620	700	260	300	210	253
JBKE72	640	720	525	565	220	270
JBKE83	750	830	270	310	220	263
JBKE85	760	850	500	565	300	375
JBKE90	820	900	850	930	340	420
JBKE95	915	950	360	425	195	280



JBKA85



JBKE85



JBKA70

The standard colour scheme for the 'K' Series is a red door with a black body. However, other colour schemes are available and are denoted by the third and fourth digit of the product coding.

Los colores estándar de la serie K consisten de puerta roja y caja negra. Sin embargo tenemos otros combinaciones de colores disponibles. Véase los códigos abajo.

Type	Door Colour	Body Colour	Icons
KE	Red	Black	Fire extinguisher, Hose reel, Breathing apparatus, * (Alarm)
KB	Black	Black	Fire extinguisher, Hose reel, Breathing apparatus, * (Alarm)
KR	Red	Red	Fire extinguisher, Hose reel, Breathing apparatus, * (Alarm)
KA	Green	Black	Fire extinguisher, Hose reel, Breathing apparatus, Spill kit
KY	Yellow	Black	Fire extinguisher, Hose reel, Breathing apparatus, Spill kit

*90 Series only / Sólo Serie 90

K Series**Serie K****Emergency key facility fitment**

The key for the cabinet is located behind a clear plate, that is held in place with two plastic fasteners. In an emergency the clear plate can be broken away, providing access to the key for the cabinet. A new clear plate can be re-attached using the same plastic fasteners.

Instalación de la ventanilla rompible en caso de emergencia

La llave del armario se encuentra detrás de una ventanilla transparente que está fijada por dos tornillos de plástico. En caso de emergencia rompe la ventanilla para acceder a la llave. Se puede instalar una nueva ventanilla con los mismos tornillos de plástico.

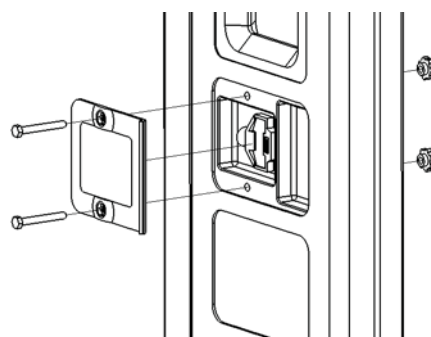

JBKE70

**Factory fitted alarm**

A reed switch activated 120 dB self contained 9 V alarm with three minute automatic reset upon activation. Alarm does not interfere with use of equipment. Coding example: JBKE70A.

Alarma de serie

Alarma independiente de 9 V activada por interruptor de lengüeta de 120 dB con reactivación automática cada 3 minutos una vez en funcionamiento. La alarma no interfiere en la utilización de la caja.

