



	 mm	 mm	 mm	 kg	
JBS130-COYE	750	850	500	12	130
JBS200-COYE	885	1005	590	16.5	200

- For indoor/outdoor storage of grit, sand, salt, chemical & spillage equipment.
- Space saving, slim-line design.
- Easy to access.
- Forklift access.
- Stackable, for easy transportation.
- Double logo facility.
- Lock facility (KIT104)

- Pour stockage à l'intérieur comme à l'extérieur de sable, sel, produit absorbant ou tout autre produit chimique.
- Économie d'espace favorisée par un design optimisé.
- Large accès pour pelletage aisé.
- Passage pour fourches pour utilisation avec chariot élévateur.
- Emboîtable.
- Personnalisation possible avec logo.
- Système de fermeture (KIT104).

- für die Lagerung von Streugut, Salz, Sand, Öl- u. Chemikalienbinder, etc. in Gebäuden sowie im Freien.
- platzsparendes Design.
- benutzerfreundlich.
- mit Stapler unterfahrbar.
- stapelbar für optimierten Transport.
- zwei Logopositionen.
- Verschlusssystem (KIT104).

Black / Noir / Schwarz	Green / Vert / Grün	Yellow / Jaune / Gelb	Red / Rouge / Rot
JBS130	JBS130-COGR	JBS130-COYE	JBS130-CORE
JBS200	JBS200-COGR	JBS200-COYE	JBS200-CORE

# KIT104

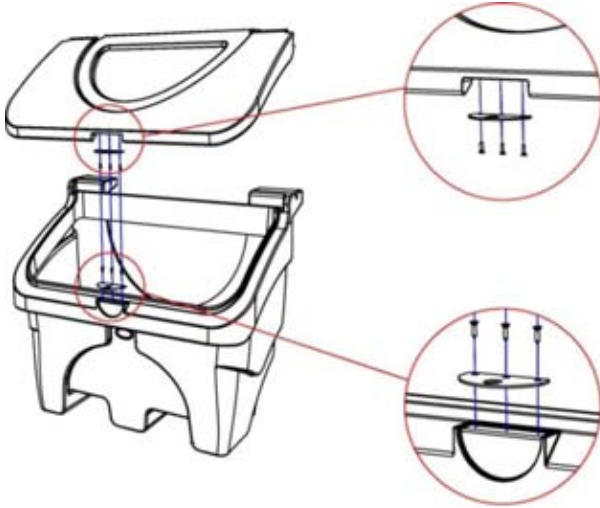

Secure the stainless steel lock plates to the lid and body using screws supplied, as illustrated above.  
Fixer les plaques de verrouillage en acier inoxydable sur le coffre et le couvercle en utilisant les vis fournies (voir schéma ci-dessus)  
Edelstahl-Schloßplatten an Deckel und Kasten mit beigefügten Schrauben wie vor sichern.

## Other Jonesco products / Autres produits Jonesco / andere Jonesco Produkte

SJ-100-001

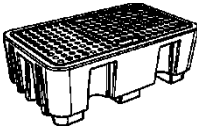

SJ-200-003

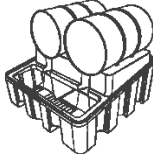

SJ-500-001

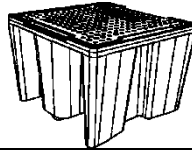

JBS400

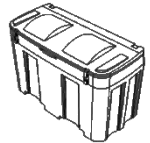

### Queries

Please contact Jonesco for any further information or assistance on fitment or other products in the Jonesco range.

#### UK

Jonesco (Preston) Ltd.  
Pittman Way, Fulwood  
Preston, Lancs.  
PR2 9ZD

Tel. +44 (0) 1772 706888  
Fax +44 (0) 1772 702209  
e-mail: [sales@jonesco-plastics.com](mailto:sales@jonesco-plastics.com)

### Informations

Pour toutes informations complémentaires ou assistance technique pour le montage de nos produits, veuillez téléphoner.

#### France

Jonesco S.A.R.L.,  
SECLIN UNEXPO  
1524 Avenue de l'Épinette,  
59113 Seclin

Tel +33 (0) 3 20 32 11 11  
Fax + 33 (0) 3 20 90 62 10  
e-mail: [jonesco@jonesco-fr.com](mailto:jonesco@jonesco-fr.com)

### Anfragen

Bitte fragen Sie an. Wir stehen Ihnen für weitere Auskünfte (bzgl. Montage/anderer Jonesco-Produkte) jederzeit zur Verfügung.

#### Deutschland

Jonesco

Tel +44 (0) 1772 706820  
Fax +44 (0) 1772 702209  
e-mail: [sales@jonesco-plastics.com](mailto:sales@jonesco-plastics.com)